

Accessories and options

PCA20xx-A1, PCIO200x-A1, PCO200x-A1, PNA200x-A1, PN1002-A1, FDCIO22x



Accessories and optional components for the EN 54-16-certified Cerberus PACE Compact digital multi-channel audio system.

- Accessories and optional components specifically tailored to the requirements of the Cerberus PACE Compact multi-channel audio system
- Media for storing and expanding the audio library of a Cerberus PACE Compact system
- I/O interfaces for expanding the inputs and outputs of digital audio matrices
- Components for automatic volume control
- Components for monitoring remote system components for open lines, ground faults, and short-circuits
- DC/DC converter for protecting remote system components from short-circuit on the external power supply
- Insulation components for isolating and maintaining the function of speakers in the event of a short-circuit on a speaker line
- Network repeater for galvanic isolation of network lines in the 'PACE-Bus'

ATP AF2GUD-2* SD 2 GB Card PCA2002-A1 (Preferred)****Swissbit SFSD2048N1 SD 2 GB Card PCA2017-A1 (Second source)**

The SD cards PCA2002-A1 and PCA2017-A1 are digital micro SD memory cards with a capacity of 2 gigabytes. The cards store up to 3 hours' worth of audio files. The cards can hold up to 256 individual audio files. The SD cards satisfy the industry standard, providing a guaranteed data storage period of over 10 years.

The SD cards PCA2002-A1 and PCA2017-A1 can be mounted in all audio matrices PC200x-A1, the 'Voice alarm panel Compact 400' PC1001-A3, the 'Voice alarm panel Compact 1000' PC1002-A3 and the 'PACE-Net' call stations PT2001-A1 and PT2002-A1.

Call stations / operating terminals**Ground fault monitoring (24V) PCA2001-A1**

The ground fault monitoring (24 V) PCA2001-A1 is a module for monitoring 24 V lines outside of the system cabinets for supplying remote system components (e.g., call stations). It measures the resistance of both wires in the lines to the protective conductor (PE).

According to the corresponding standard, a ground fault is detected when a resistance of <50 kOhm is measured to the protective conductor. A fault message is transmitted by the relay changeover contact and indicated on the printed circuit board via LED.

MeanWell SD-50B-24 DC/DC PCA2011-A1**MeanWell SD-100B-24 DC/DC PCA2018-A1**

The DC/DC converters PCA2011-A1 and PCA2018-A1 are required to electrically isolate DC 24 V lines exiting the system cabinet from the internal DC 24 V power supply. Any short-circuit or ground fault that occurs outside the system cabinet will therefore not affect the internal 24 V supply.

The devices are protected against short-circuits, overload and overvoltage.

I/O interfaces**Input/Output extension (digital 16) PCIO2001-A1**

The 'Input/Output extension (digital 16)' PCIO2001-A1 extends the number of digital inputs and outputs for each audio matrix by additional 16 inputs and 16 outputs.

It was specifically developed for use with all digital audio matrices PC200x-A1, the 'Voice alarm panel Compact 400' PC1001-A3 and the 'Voice alarm panel Compact 1000' PC1002-A3.

The PCIO2001-A1 and the audio matrix are connected via the 'PACE-Bus' (RS485).

Input/output module (digital, 16) PCIO2002-A1

The 'Input/output module (digital, 16)' PCIO2002-A1 extends the number of inputs and outputs for each audio matrix by additional 16 digital inputs, 8 analog inputs and 8 electrically isolated relay outputs.

Each relay offers 2-pole changeover contacts. All contacts, NC, NO and center are routed to terminals.

Further 8 relay outputs can be added by connecting an 'Output extension (relay, 8)' PCO2003-A1 module directly to this module.

It was specifically developed for use with all digital audio matrices PC200x-A1, the 'Voice alarm panel Compact 400' PC1001-A3 and the 'Voice alarm panel Compact 1000' PC1002-A3.

The connection between the PCIO2002-A1 and the audio matrix is established via the 'PACE-Bus' (RS485).

Output module (relay, 8) PCO2002-A1

The 'Output module (relay, 8)' PCO2002-A1 extends the number of digital outputs for each audio matrix by additional 8 electrically isolated relay outputs.

Each relay offers 2-pole changeover contacts. All contacts, NC, NO and center are routed to terminals.

Further 8 relay outputs can be added by connecting an 'Output extension (relay, 8)' PCO2003-A1 module directly to this module.

It was specifically developed for use with all digital audio matrices PC200x-A1, the 'Voice alarm panel Compact 400' PC1001-A3 and the 'Voice alarm panel Compact 1000' PC1002-A3.

The connection between the PCO2002-A1 and the audio matrix is established via the 'PACE-Bus' (RS485).

Output extension (relay, 8) PCO2003-A1

The 'Output extension (relay, 8)' PCO2003-A1 extends the number of digital outputs for each audio matrix by additional 8 electrically isolated relay outputs.

Each relay offers 2-pole changeover contacts. All contacts, NC, NO and center are routed to terminals.

One PCO2003-A1 connects to a PCIO2002-A1 or a PCO2002-A1 via an attached flat band cable.

Automatic volume control

The 'Automatic Volume Control' (AVC) function is used to supervise the ambient noise of an area and increase the volume of the speaker line in case that the ambient noise is higher than the predefined value, such as on train stations, in airports and in shopping malls.

The AVC function is required as a way of adjusting the sound level of the audio signal to suit the current situation in the event of huge fluctuations in background noise. This ensures that the wanted signal is always louder than any background noise so that it will be possible to understand what is being said and on the other hand, announcements will not be too loud for people in quiet buildings.

Automated volume control module PCA2008-A1

The 'Automated volume control module' PCA2008-A1 receives the audio level of the measuring microphones PCA2007-A1. The PCA2008-A1 uses the received audio levels to calculate the average, which is then forwarded to the connected audio matrix for further processing. The input sensitivity can be set to line level or microphone level.

It is possible to connect up to four PCA2007-A1 to one PCA2008-A1. The connected microphone wiring is monitored for short-circuits, interruptions and earth faults. Inactive lines can be excluded via jumper. A fault is reported with the fault indication relay.

The PCA2008-A1 was specifically developed for use with the digital audio matrices PC2001-A1, PC2003-A1, PC2005-A1, as well as the 'Voice alarm panel Compact 400' PC1001-A3 and the 'Voice alarm panel Compact 1000' PC1002-A3.

Automated volume control microphone PCA2007-A1

The AVC microphone PCA2007-A1 is a measuring microphone that was specifically developed for use with the digital audio matrices PC2001-A1, PC2003-A1, PC2005-A1, as well as the 'Voice alarm panel Compact 400' PC1001-A3 and the 'Voice alarm panel Compact 1000' PC1002-A3. It constantly records the levels in the surrounding area within a set frequency range and transmits the value to the receiver assembly PCA2008-A1 for further processing.

The output level can be set to line level or microphone level.

EOL3 (active) PCA2004-A1

The 'EOL3 (active)' PCA2004-A1 ensures that the speaker lines are monitored without interruption in accordance with EN 54-16.

The device is addressable. The 16 addresses are created by DIP switch.

Up to 16 PCA2004-A1 can be connected per speaker line and amplifier. The PCA2004-A1 was specifically developed for use with the digital audio matrices PC2001-A1, PC2002-A1, PC2003-A1, as well as the 'Voice alarm panel Compact 400' PC1001-A3 and the 'Voice alarm panel Compact 1000' PC1002-A3.

Loop isolators

Loop isolator (100V) PCA2005-A1

The loop isolator (100 V) PCA2005-A1 is an isolating element in accordance with EN 54-17 for use in a 100 V speaker line. The isolator rapidly detects and isolates short-circuits affecting the line. It monitors the speaker line connected to the loop isolator for open lines and short-circuits. The status of the PCA2005-A1 is shown on an optical display.

Two-pole standard wires are used as cables for the speaker loop. Up to 120 loop isolators can be connected to a speaker line loop (depending on the connected amplifier). The maximum loop length is 1000 m per amplifier output.

The PCA2005-A1 was specifically developed for use with the digital audio matrix PC2003-A1, as well as the 'Voice alarm panel Compact 400' PC1001-A3 and the 'Voice alarm panel Compact 1000' PC1002-A3.

Spelsberg i 16-L loop isolator Box PCA2013-A1

IP55 housing for loop isolator (100 V) PCA2005-A1. It is required for the PCA2005-A1 to meet the EN 54-17.

PACE-Net

The Cerberus PACE Compact 'PACE-Net' network is based on a standard Ethernet with 100 Mbit/sec and CAT5 copper cables.

Camdenboss RJ45 Interface PNA2008-A1

A standard CAT5 Ethernet cable comes with a standard RJ45 connector. PNA2008-A1 is an interface from RJ45 connector to screw terminals to connect cables with single wires (e.g. E30).

PACE-Bus

ICPDAS I-7510 (RS485, isolated) PNA2009-A1

The isolated RS485 repeater PNA2009-A1 is required to electrically isolate 'PACE-Bus' (RS485) signals exiting the system cabinet from the internal 'PACE-Bus' (RS485). Any short-circuit that occurs outside the system cabinet will therefore not affect the internal 'PACE-Bus' (RS485).

The PNA2009-A1 requires a supply voltage of DC 24 V.

RS485 module (1 port) PN1002-A1

The 'RS485 module (1 port)' PN1002-A1 is used for a convenient connection of external 'PACE-Bus' (RS485) components. It provides the following electrically isolated signals:

- 'PACE-Bus' (RS485) communication
- DC 24 V power supply voltage with ground fault detection
- Analog audio input
- Analog audio output

Any short-circuit on the connected wiring which occurs outside of the system cabinet will therefore not affect the internal signals.

One PN1002-A1 plug-in module can be mounted on a digital audio matrix board.

Input/output module FDnet/C-NET FDCIO221/FDCIO222/FDCIO223/FDCIO224

The input/output modules FDnet/C-NET FDCIO221/FDCIO222/FDCIO223/FDCIO224 can be used to connect outputs and inputs of the Cerberus PACE Compact system with a Cerberus Pro fire system. The outputs are used to send status and other information to the fire system and the inputs are used to get control information from the fire system.

The modules can be mounted in the Cerberus PACE Compact cabinets.

Other accessories

TAS ULE-614 Dialer PCA2015-A1

The PCA2015-A1 is a Gateway between the telephone system (VoIP) and Cerberus PACE Compact. It provides an audio communication over the telephone system and the Cerberus PACE Compact via electrically isolated analog audio input and analog audio output. The Cerberus PACE Compact system can be controlled with 2 remote controlled electrically isolated digital output contacts. The PCA2015-A1 has 2 digital inputs to send status information. On a status change the PCA2015-A1 calls up to 3 pre-configured telephone numbers automatically.

The PCA2015-A1 comes with LAN interface 10/100 Base T(x) (VoIP with SIP-Protocol).

Müller SC 95.47 PRO Clock PCA2016-A1

The PCA2016-A1 is a main clock for the Cerberus PACE Compact system. It provides clock pulses to synchronize the connected system. The programming package is included in the product package. With an additional DCF77 or GPS radio receiver the time can be set and adjusted automatically.

The PCA2016-A1 comes in a 19" housing and can't be mounted in a Cerberus PACE Compact cabinet.

ITEC CD/USB/SD-Player PCA2019-A1

An PCA2019-A1 is a message or music player for the standard application. It is a player offering a front-loading CD drive, a USB-plug and a SD-Card slot. The PCA2019-A1 offers a LCD-display, direct track access buttons, program, random and repeat functions and an infrared remote control device.

It shall not be used for evacuation messages. The PCA2019-A1 comes in a 19" housing and can't be mounted in a Cerberus PACE Compact cabinet.

Features and Functions

Extras (Preferred)

NOTICE! These extras are to be preferably ordered.

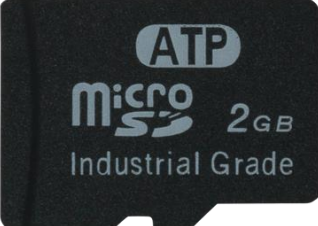

PCA2002-A1	'ATP AF2GUD-2*** SD 2 GB Card'
	<ul style="list-style-type: none"> • 2 GB micro SD memory card • Up to 256 audio files with a total duration of 3 h • For industrial applications • Water-tight • Dust-tight • Guaranteed data storage: >10 years

Extras (Second source)

NOTICE! Order alternatives only if the preference is not available.

PCA2017-A1	'Swissbit SFSD2048N1 SD 2 GB Card'
	<ul style="list-style-type: none"> • 2 GB micro SD memory card • Up to 256 audio files with a total duration of 3 h • For industrial applications • Water-tight • Dust-tight • Guaranteed data storage: >10 years

Call stations / operating terminals

PCA2001-A1	'Ground fault monitoring (24V)'
	<ul style="list-style-type: none"> • Monitoring of the DC 24 V line for ground faults • Used with remote system components (Required when the 24 V line exits the system cabinet to supply energy to components such as the fire brigade microphone) • Fault message via relay changeover contact (Fault / Okay) • Fault indicated via LED on module • Switch to a lower sensitivity of 10 kOhm via jumper setting • Installation in a system cabinet (TS35 DIN-rail-ready) • All connections on plug-in terminal blocks
PCA2011-A1	'MeanWell SD-50B-24 DC/DC'
	<ul style="list-style-type: none"> • Controlled DC 24 V (50 W) output voltage, electrically isolated • Internal 24 V energy supply protected against short-circuits on the external 24 V supply line outside the system cabinet • Protected against short-circuit, overloading and overvoltage • DC 1500 V I/O isolation • 100 % full load burn-in test • Fixed switch frequency of 83 kHz

PCA2018-A1	'MeanWell SD-100B-24 DC/DC'
	<ul style="list-style-type: none"> • Controlled DC 24 V (100 W) output voltage, electrically isolated • Internal 24 V energy supply protected against short-circuits on the external 24 V supply line outside the system cabinet • Protected against short-circuit, overloading and overvoltage • DC 1500 V I/O isolation • 100 % full load burn-in test • Fixed switch frequency of 83 kHz

I/O interfaces

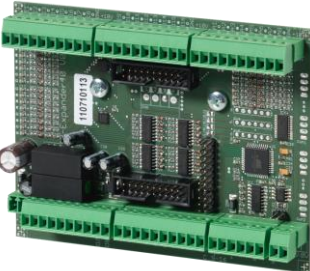

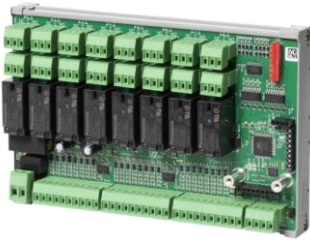
PCIO2001-A1	'Input/Output extension (digital 16)'
	<ul style="list-style-type: none"> • For use with all digital audio matrices • Communication via 'PACE-Bus' (RS485) or (RS232) interfaces • Extends a digital audio matrix by additional 16 digital outputs • Outputs are electrically isolated • Extends a digital audio matrix by additional 16 digital inputs • Extends a digital audio matrix by additional 8 analog inputs

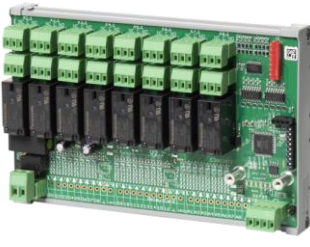
PCIO2002-A1	'Input/output module (digital, 16)'
	<ul style="list-style-type: none"> • For use with all digital audio matrices • Communication via 'PACE-Bus' (RS485) interfaces • Extends a digital audio matrix by additional 16 digital inputs • Extends a digital audio matrix by additional 8 analog inputs • Extends a digital audio matrix by additional 8 digital relay outputs • The component includes 8 relays with 2-pole changeover contacts • The maximum permissible switching current for each changeover contact is 5 A / 100 V • Installation in the system cabinet (TS35 DIN-rail-ready)

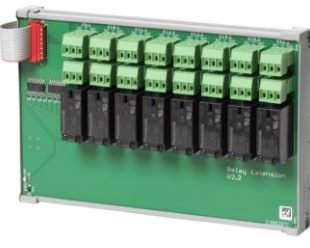
PCO2002-A1	'Output module (relay, 8)'
	<ul style="list-style-type: none"> • For use with all digital audio matrices • Communication via 'PACE-Bus' (RS485) interfaces • Extends a digital audio matrix by additional 8 digital relay outputs • The component includes 8 relays with 2-pole changeover contacts • The maximum permissible switching current for each changeover contact is 5 A / 100 V • Installation in the system cabinet (TS35 DIN-rail-ready)

PCO2003-A1	'Output extension (relay, 8)'
	<ul style="list-style-type: none"> • Extension module for PCIO2002-A1 and PCO2002-A1 • Communication via 'PACE-Bus' (RS485) interfaces • Extends a digital audio matrix by additional 8 digital relay outputs • The component includes 8 relays with 2-pole changeover contacts • The maximum permissible switching current for each changeover contact is 5 A / 100 V • Installation in the system cabinet (TS35 DIN-rail-ready)



Automatic volume control

PCA2008-A1	'Automated volume control module'
 <p>The image shows a green printed circuit board (PCB) for the PCA2008-A1 module. It features several green terminal blocks at the top and bottom for wiring. A central black component, likely a microcontroller or sensor, is mounted on the board. Various electronic components like resistors and capacitors are visible on the surface.</p>	<ul style="list-style-type: none"> • Supports automatic volume control to suit levels of background noise • Measures the noise level in a designated area • Connects up to four microphones PCA2007-A1 • Supports microphone and line level • Supplies the connected microphones with DC 12 V phantom voltage • Monitors the microphone wiring for short, interruption and ground fault • Fault message via relay changeover contact (Fault / Okay) • Installation in the system cabinet (TS35 DIN-rail-ready) • All connections on plug-in terminal blocks • For use with the digital audio matrices PC2001-A1, PC2003-A1, PC2005-A1, as well as the 'Voice alarm panel Compact 400' PC1001-A3 and the 'Voice alarm panel Compact 1000' PC1002-A3
PCA2007-A1	'Automated volume control microphone'
 <p>The image shows a white, rectangular, IP54-protected enclosure for the PCA2007-A1 microphone. It has a circular microphone grille on the front face and a 3-pin terminal block at the bottom. The enclosure is mounted on a DIN rail.</p>	<ul style="list-style-type: none"> • Supports automatic volume control to suit levels of background noise • For use with the digital audio matrices PC2001-A1, PC2003-A1, PC2005-A1, as well as the 'Voice alarm panel Compact 400' PC1001-A3 and the 'Voice alarm panel Compact 1000' PC1002-A3 • Connection to PCA2008-A1 with a 3-pin terminal • Power supply via phantom voltage through automatic volume control module PCA2008-A1 (no separate power supply required) • Electret microphone in an IP54 protective housing • Symmetrical output: selectable microphone / line level • Microphone or line level (high resistance to faults) • Simple mounting and installation • Linear frequency band of 100 Hz to 10 kHz

EOL modules

PCA2004-A1	'EOL3 (active)'
 <p>The image shows a small, black, rectangular module for the PCA2004-A1. It has a label with the text 'EOL 3', 'SN: 1796', 'HW: 1.0', and 'SW: 1.0'. Two red and black wires are connected to the module. It has a mounting bracket on the side.</p>	<ul style="list-style-type: none"> • Monitoring the speaker line for open lines and short-circuits • Monitoring in accordance with EN 54-16 • Addressable: up to 16 different addresses can be configured • Addressing compatible with any structure with up to 16 line ends, in addition to the stub line • Reliable cable break detection in any branch of a speaker line • No other wiring needed; works with standard two-wire speaker line • No need to route line back to control panel

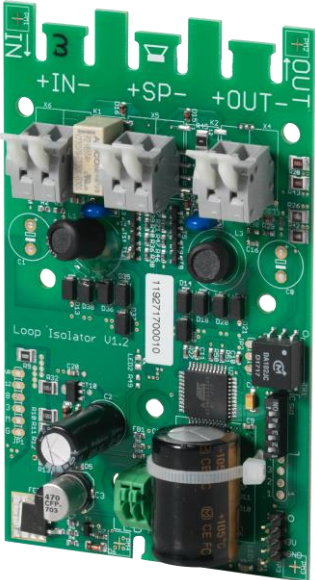

Loop isolators



PCA2005-A1	'Loop isolator (100V)'
 A green printed circuit board (PCB) for a loop isolator. It features three RJ45 ports at the top labeled '+IN-', '+SP-', and '+OUT-'. Below the ports are two potentiometers and a large black electrolytic capacitor. The board is populated with various electronic components including resistors, capacitors, and integrated circuits. The text 'Loop Isolator V1.2' and '119271700010' are visible on the board.	<ul style="list-style-type: none">• Isolating element in accordance with EN 54-17 for use in a 100 V speaker line with PC2003-A1, as well as the 'Voice alarm panel Compact 400' PC1001-A3 and the 'Voice alarm panel Compact 1000' PC1002-A3• Rapidly detects and isolates short-circuits affecting the 100 V speaker line• Monitors the speaker and cables connected to the loop isolator for open lines and short-circuits• Two-pole standard lines used as cables for the speaker loop• Optical display of isolator status
PCA2013-A1	'Spelsberg i 16-L loop isolator Box'
 A white, rectangular plastic housing for a loop isolator. It has a hinged lid on the top and a series of circular ventilation holes on the right side. The front panel is plain white with some faint markings.	<ul style="list-style-type: none">• Housing for loop isolator (100 V) PCA2005-A1• IP55

PACE-Net



PNA2008-A1	'Camdenboss RJ45 Interface'
 A green plastic RJ45 interface module. It features an RJ45 port at the top and a 35 mm DIN rail mounting base at the bottom. The base has several screw terminals labeled '1', '2', '3', '4', '5', '6', '7', and 'SHLD'. The module is designed for easy installation on a DIN rail.	<ul style="list-style-type: none">• Interface from RJ45 connector to screw terminals• 35 mm DIN rail mounting

PACE-Bus

<p>PN1002-A1</p>  <p>The image shows a green printed circuit board (PCB) for the PN1002-A1 module. It features a green terminal block at the top with five pins. Below it are various electronic components including resistors, capacitors, and integrated circuits. Two large black transformers are mounted on the board, labeled '1907' and 'SEC'. At the bottom, there are two black connectors for DIN rail mounting.</p>	<p>'RS485 module (1 port)'</p> <ul style="list-style-type: none"> • 1x 'PACE-Bus' (RS485) port • 2-way optical isolated 'PACE-Bus' (RS485) repeater • Provides controlled DC 24 V electrically isolated output • Provides electrically isolated analog audio input • Provides electrically isolated analog audio output • Monitoring of the DC 24 V line for ground faults • Plug-in module for Cerberus PACE Compact digital audio matrix boards
<p>PNA2009-A1</p>  <p>The image shows a blue plastic DIN rail module, model PNA2009-A1. The front panel is grey and features the 'ICP CON' logo and the model number 'I-7510'. It is labeled as an 'RS-485 Repeater' with '3000V Isolation'. The module has two rows of gold-plated terminals on top and bottom for DIN rail mounting.</p>	<p>'ICPDAS I-7510 (RS485, isolated)'</p> <ul style="list-style-type: none"> • 2-way optical isolated 'PACE-Bus' (RS485) repeater • 35 mm DIN rail mounting
<p>I/O modules</p>	
<p>FDCIO221</p>  <p>The image shows a white plastic DIN rail module, model FDCIO221. It is a Siemens module, as indicated by the logo on the front. The module has a green terminal block at the top and a white terminal block at the bottom. It features a central LED indicator and various status indicators.</p>	<p>'Input/output module FDnet/C-NET'</p> <ul style="list-style-type: none"> • Input/output module FDCIO221: <ul style="list-style-type: none"> – Control output with potential-free relay contact for activation of alarming devices, fans, air conditioning systems, lift controls, etc. – Monitored contact input for reporting technical statuses or activating an alarm – Use as a monitored output with a separate power supply, e.g., for operating acoustic signal transmitters • LED indicator for input/output statuses and for fault, test and localization • Power supply and communication via FDnet/C-NET (addressed individually) • Address automatically issued during commissioning • Two-wire installation for all cable types

FDCIO222	'Input/output module FDnet/C-NET'
	<ul style="list-style-type: none"> ● Input/output module FDCIO222: <ul style="list-style-type: none"> – Four control outputs with potential-free relay contacts for activation of fire doors, fans, air conditioning systems, lift controls, etc. – Four monitored contact inputs for confirming technical statuses or activating an alarm ● LED indicator for input/output statuses and for fault, test and localization ● Power supply and communication via FDnet/C-NET (addressed individually) ● Address automatically issued during commissioning ● Two-wire installation for all cable types
FDCIO223	'Input/output module FDnet/C-NET'
	<ul style="list-style-type: none"> ● Two monitored inputs/outputs, which can optionally be used as follows: <ul style="list-style-type: none"> – Collective detector line/conventional detector line – Contact input – Control output – Control output with confirmation ● LED indicator for input/output statuses and for fault, test and localization ● Power supply and communication via FDnet/C-NET (addressed individually) ● Address automatically issued during commissioning ● Two-wire installation for all cable types ● Pluggable connection terminals ● DC 24 V external power supply (detector lines electrically isolated) ● Microprocessor-controlled signal processing ● Communication via FDnet/C-NET (addressed individually)
FDCIO224	'Input/output module FDnet/C-NET'
	<ul style="list-style-type: none"> ● Input/output module FDCIO224: <ul style="list-style-type: none"> – Four control outputs with potential-free relay contacts for activation of fire doors, fans, air conditioning systems, lift controls, etc. – Four monitored contact inputs for confirming technical statuses ● LED indicator for input/output statuses and for fault, test and localization ● Power supply and communication via FDnet/C-NET (addressed individually) ● Address automatically issued during commissioning ● Two-wire installation for all cable types

Other accessories

PCA2015-A1	'TAS ULE-614 Dialer'
	<ul style="list-style-type: none"> ● Gateway between telephone system (VoIP) to analog audio ● LAN interface 10/100 Base T(x) (VoIP with SIP-Protocol) ● Analog audio input and output, potential-free ● 2 remote controlled potential-free digital output contacts ● 2 digital inputs
PCA2016-A1	'Müller SC 95.47 PRO Clock'
	<ul style="list-style-type: none"> ● Masterclock for approximately 200 slave clocks (DC 24 V, 1.5 A, pole changing pulse) ● Power supply with AC 230 V or DC 24 V ● Integrated DC 24 V power supply unit for slave clock pulses and GPS receiver operation ● Included accessories data-key DK pro and programming package PP50 pro / PP60 pro ● Optional accessories DCF77 and GPS radio receivers ● 19" / 2 HU housing ● An additional 19" cabinet is required for the Cerberus PACE Compact system
PCA2019-A1	'ITEC CD/USB/SD-Player'
	<ul style="list-style-type: none"> ● Controls clearly arranged ● Front-loading CD drive ● USB plug and SD plug ● LCD display ● Infrared remote control ● Programmable playback, random play, repeat function ● Stereo outputs on RCA plugs ● 19" / 1 HU housing ● An additional 19" cabinet is required for the Cerberus PACE Compact system

Order numbers

Type	Designation	Order number
Preferred extras¹		
PCA2002-A1	ATP AF2GUD-2*** SD 2 GB	S54451-B20-A1
Second source extras¹		
PCA2017-A1	Swissbit SFSD2048N1 SD 2 GB	S54451-B20-B1
Accessories for operating terminals / call stations		
PCA2001-A1	Ground fault monit. (24V)	S54451-B19-A1
PCA2011-A1	MeanWell SD-50B-24 DC/DC	S54451-B65-A1
PCA2018-A1	MeanWell SD-100B-24 DC/DC	S54451-B75-A1
I/O interfaces		
PCIO2001-A1	IN/OUT extent. (digital 16)	S54451-B28-A1
PCIO2002-A1	Input/output mod (dig., 16)	S54451-B78-A1
PCO2002-A1	Output module (relay, 8)	S54451-B79-A1
PCO2003-A1	Output extension (relay, 8)	S54451-B80-A1
Automatic volume control		
PCA2008-A1	Autom. volume control module	S54451-B26-A1
PCA2007-A1	Autom. volume control micro	S54451-B25-A1
EOL modules		
PCA2004-A1	EOL3 (active)	S54451-B22-A1
Loop isolators		
PCA2005-A1	Loop isolator (100V)	S54451-B53-A1
PCA2013-A1	Spelsberg i 16-L Li Box	S54451-B54-A1
Accessories for 'PACE-Net'		
PNA2008-A1	Camdenboss RJ45 Interface	S54451-B40-A1
Accessories for 'PACE-Bus'		
PN1002-A1	RS485 module (1 port)	S54451-B207-A1
PNA2009-A1	ICPDAS I-7510 (RS485, isol)	S54451-B30-A1

Type	Designation	Order number
Fire components for connection of a fire detection panel		
FDCIO221	Input/output module FDnet/C-NET	S54312-F2-A1
FDCIO222	Input/output module FDnet/C-NET	A5Q00002369
FDCIO223	Input/output module FDnet/C-NET	S24218-B102-A1
FDCIO224	Input/output module FDnet/C-NET	A5Q00018689
Other accessories		
PCA2015-A1	TAS ULE-614 Dialer	S54451-B81-A1
PCA2016-A1	Müller SC 95.47 PRO Clock	S54451-B82-A1
PCA2019-A1	ITEC CD/USB/SD-Player	S54451-B83-A1

1

- The preferred components are to be ordered preferably.
- Order the alternative second source components only in case the preference is not available.

You will find more information on the Cerberus PACE Compact system and its components in the following documents:

Title	Document ID
IT security policies	
Cerberus PACE Compact – IT security policies	A6V11439692
System documentation	
Cerberus PACE Compact – planning	A6V11899877
'PACE-Design' – configuration	A6V10429097
Cerberus PACE Compact – mounting / installation	A6V11899867
Cerberus PACE Compact – operation	A6V11899865
Data sheets	
System data sheet	A6V11868429
Voice alarm panel Compact 400	A6V11940263
Voice alarm panel Compact 1000	A6V11940268
Network components	A6V11940273
Operating and call stations	A6V11940274
Power supply and batteries	A6V11940272
Accessories and options	A6V11940275
Loop isolator (100V)	
Loop isolator (100V) - technical manual	A6V11571319
Environmental declaration	
Cerberus PACE – environmental declaration	A6V11948779
Cerberus PACE Compact – environmental declaration	A6V12161830

Download center

Related documents such as environmental declarations, CE declarations, etc., can also be downloaded at the following Internet address:



<http://siemens.com/bt/download>

Notes

Safety

	⚠ CAUTION
	National safety regulations Failure to comply with national safety regulations may result in personal injury and property damage. <ul style="list-style-type: none">• Observe national provisions and comply with the appropriate safety regulations.

Disposal

 	The device is considered an electronic device for disposal in accordance with the European Guidelines and may not be disposed of as domestic garbage. <ul style="list-style-type: none">• Dispose of the device through channels provided for this purpose.• Comply with all local and currently applicable laws and regulations.
--	--

Environmental compatibility

The Environmental Product Declarations (EPDs) for 'Cerberus PACE VANSYS' and 'Cerberus PACE Compact VANSYS' contain data and information on the product's environmentally compatible design features and its ratings; for example, its RoHS conformity, composition, packaging, environmental benefits, and disposal information.

You can obtain the documents A6V11948779/A6V12161830 via the following Internet address:

<https://siemens.com/bt/download>

Enter the document ID in the search field.

Guarantee

The application-specific technical data is guaranteed only in combination with 'Cerberus PACE' and 'Cerberus PACE Compact' Siemens products. If third-party products are used, any guarantee provided by Siemens will be invalidated.

SD card

	PCA2002-A1	PCA2017-A1
Ordering	Preferred	Second source
Supply		
Power supply	2.7...3.6 V	2.7...3.6 V
Current consumption	<50 mA	<110 mA
Cycle frequency	50 Mhz max.	50 Mhz max.
Performance data		
Storage capacity	2 GB	2 GB
Number of insertions	At least 10,000 insertions	At least 20,000 insertions
Data storage period	10 years	10 years
Service life	10,000 sequences (read/write/delete)	10,000 sequences (read/write/delete)
Shock resistance	1000 G	1500 G
Vibration	Maximum 15 G peak-to-peak	Maximum 50 G peak-to-peak
Resistance	Water-tight Dust-tight ESD protection	
Interfaces		
Plug-in contacts	8 pins	
Ambient conditions		
Operating temperature	0...+70 °C	-25...+85 °C
Storage temperature	0...+70 °C	-25...+85 °C
Operation in humid environments (without moisture condensation)	10...90 % rel.	10...85 % rel.
Storage in humid environments (without moisture condensation)	5...90 % rel.	5...85 % rel.
Dimensions and weights		
W x H x D mm	11 x 1 x 15 (+/- 0.1)	
Weight	0.4 g	

Ground fault monitoring (24 V)

	PCA2001-A1
Supply	
Power supply	DC 24 V (corresponds to the voltage to be monitored)
Current consumption	100 mA
Threshold	50 kohm (10 kohm if JP1 and JP2 closed)
Relay contact	Max. 48 V / 500 mA
Fault indicator relay	Changeover contact (fault / OK) Can be switched to a lower sensitivity of 10 kohm for each jumper
Ambient conditions	
Operating temperature	-5...+40 °C
Storage temperature	-20...+70 °C
Operation in humid environments (without moisture condensation)	10...90 % rel.
Storage in humid environments (without moisture condensation)	5...90 % rel.
Housing type	Open frame design
Mounting	DIN rail mounting (TS35)
Dimensions and weights	
W x H x D mm	75 x 70 x 40
Weight	100 g
Standards	EN 54-16

DC/DC converter

	PCA2011-A1	PCA2018-A1
Output		
Nominal output voltage	DC 24 V	DC 24 V
Maximum output current	2.1 A	4.2 A
Nominal output	50.4 W	100.8 W
Residual ripple and noise	150 mVp-p	150 mVp-p
Adjustable output voltage range	DC 23...30 V	DC 23...30 V
Input		
Voltage range	DC 19...36 V	DC 19...36 V
Input current	3.0 A / 24 V	4.8 A / 24 V
Efficiency	80 % / 24 V	78 % / 24 V
Protection		
Overload*	105...150 % nominal output	105...135 % nominal output
Overvoltage*	31.5...37.5 V / 10 % load	31.5...37.5 V / 10 % load
* Protection category: Hiccup mode, automatically recovers once error has been resolved		
Ambient conditions		
Operating temperature	-10...+60 °C	
Storage temperature	-20...+85 °C	
Operation in humid environments (without moisture condensation)	20...90 %	
Storage in humid environments (without moisture condensation)	10...95 %	
Temperature coefficient	±0.03 % / °C	
Vibration	10...500 Hz, 2G 10min. / 1 cycle, 60 min. on the X, Y or Z axis	
Dimensions and weights		
W x H x D mm	159 x 38 x 97	199 x 38 x 98
Weight	480 g	650 g

	PCA2011-A1	PCA2018-A1
Security		
Electric strength	I/P-O/P: 1.5 kVAC I/P-FG: 1.5 kVAC O/P-FG: 0.5 kVAC	I/P-O/P: 1.5 kVAC I/P-FG: 2.0 kVAC O/P-FG: 0.5 kVAC
Insulation resistance	I/P-O/P, I/P-FG, O/P-FG: 100 Mohm / DC 500 V / 25 / 70 % RH	
MTBF	At least 357,500 h / 25 °C	At least 356,700 h / 25 °C
Standards	EN 55032: 2015, class B EN 61000-4-2,3,4,5,6,8	

I/O interfaces

Input/output module

	PCIO2001-A1	PCIO2002-A1
Supply		
Power supply	DC 24 V (18 V <36 V)	DC 24 V (18 V <36 V)
Current consumption	56 mA	56 mA/200 mA when 8 relays are active
Internal power supply	DC 10 V	DC 12 V
Maximum load	100 mA / DC 10 V	100 mA / DC 12 V
Digital control inputs		
Logic level	Logic off: <1.6 V Logic on: >8 V	Logic off: <3.0 V Logic on: >7 V
Input voltage range	DC 0...36 V	DC 0...30 V
Input current at 12 V / 24 V	0.5 mA at 12 V 1 mA at 24 V	0.5 mA at 12 V 1 mA at 24 V
Digital control outputs		
Number and type	16 electrically isolated open collector outputs	8 electrically isolated relay outputs with 2-pole changeover contacts
Max. voltage	DC 35 V	AC 100 V, DC 30 V
Max. current per output	80 mA	5 A
Isolation voltage	3.75 kV	10 kV

	PCIO2001-A1	PCIO2002-A1
Analog control inputs		
Input voltage range	DC 0...10 V	DC 0...10 V
Number	8 (max. 15 / matrix)	8
Resolution	8 bit	8 bit
Input current at 10 V	0.2 mA	0.2 mA
Interface RS485		
Serial interface to matrices	1x RS485	
Baud rate	9600, 19200, 56700, 115200 Baud	
Module connections	Up to 4 modules via RS485	
Max. cable length	500 m	
Interface RS232		
Baud rate	19200 Baud	-
Module connections	1 module via RS232	-
Max. cable length	3 m	-
Ambient conditions		
Operating temperature	-5...+40 °C	
Storage temperature	-20...+70 °C	
Operation in humid environments (without moisture condensation)	10...90 % rel.	
Storage in humid environments (without moisture condensation)	5...90 % rel.	
Mounting		
Attachment	DIN rail mounting (TS35)	
Maximum conductor cross-section	1.5 mm ² Compatible with CAT5 cables (VDC+, GND, DATA+, DATA- signals)	
Dimensions and weights		
W x H x D mm	125 x 95 x 35	162 x 102 x 47
Weight	150 g	295 g
Standards	EN 54-16	

Output module

	PCO2002-A1	PCO2003-A1
Supply		
Power supply	DC 24 V (18 V <36 V)	
Current consumption	56 mA /200 mA when 8 relays are active	
Internal power supply	DC 12 V	
Maximum load	100 mA / DC 12 V	
Digital control outputs		
Number and type	8 electrically isolated relay outputs with 2-pole changeover contacts	
Max. voltage	AC 100 V, DC 30 V	
Max. current per output	5 A	
Isolation voltage	10 kV	
Interfaces		
Serial interfaces	RS485	-
Baud rate	9600, 192000, 56700, 115200 Baud	-
Module connection	Up to 4 modules via RS485	-
Max. cable length	500 m	-
Ambient conditions		
Operating temperature	-5...+40 °C	
Storage temperature	-20...+70 °C	
Operation in humid environments (without moisture condensation)	10...90 % rel.	
Storage in humid environments (without moisture condensation)	5...90 % rel.	
Mounting	DIN rail mounting (TS35)	
Dimensions and weight		
W x H x D mm	162 x 102 x 47	162 x 102 x 47
Weight	282 g	258 g
Standards	EN 54-16	

Automated volume control module

	PCA2008-A1
Supply	
Power supply	DC 24 V
Current consumption	100 mA
Microphone connection	
Max PCA2007-A1 connected	4
Microphone power supply	DC 12 V phantom power Electrically isolated from the power supply.
Microphone input sensitivity selectable	Line level or microphone level
Max. input level (MIC)	12 μ V/Pa
Max. input level (LINE)	+ 25 dB
Monitoring of each microphone wiring	Interruption, short-circuit, ground fault
Fault indicator relay	Changeover contact (fault / OK) Inactive lines can be excluded via jumper
Relay contact	Max. 48 V / 500 mA
Cable connection	Plug-in terminal blocks
Ambient conditions	
Operating temperature	-5...+40 °C
Storage temperature	-20...+70 °C
Operation in humid environments (without moisture condensation)	10...90 % rel.
Storage in humid environments (without moisture condensation)	5...90 % rel.
Housing type	Open frame design
Mounting	DIN rail mounting (TS35)
Dimensions and weights	
W x H x D mm	75 x 70 x 40
Weight	100...110 g
Standards	EN 54-16

Automated volume control microphone

	PCA2007-A1
Type	Electret microphone
Supply	
Power supply	DC 12 V phantom power (up to 48 V possible)
Current consumption	2 mA at 12 V
Cable connection	3-pin terminal: Cable gland PG 9 (cable diameter 2.5...8 mm)
Audio properties	
Frequency band	100 Hz...10 kHz +/-6 dB
Outputs:	
• Max. output level (MIC)	12 µV/Pa
• Max. output level (LINE)	+ 25 dB
• Output impedance	Symmetrical output
Ambient conditions	
Operating temperature	-5...+40 °C
Storage temperature	-20...+70 °C
Operation in humid environments (without moisture condensation)	10...90 % rel.
Storage in humid environments (without moisture condensation)	5...90 % rel.
Housing material	ABS
Dimensions and weights	
W x H x D mm	36 x 64 x 98
Weight	140 g
Protection category and color	
Protection category (IEC 60529)	IP54
Color	Light grey, comparable to RAL 7035
Standards	EN 54-16

EOL3 (active)

	PCA2004-A1
Supply	
Power supply	AC 8...100 V
Power consumption	Max. 150 mW Typ. 100 mW
Max. line output (corresponds to max. amplifier output on speaker line)	500 W
Cable connection	Max. 2x 1.5 mm ²
Maximum number of modules in use	
Max. number of modules per amplifier	16
Max. number of modules per speaker line	16
Max. number of modules per matrix	64
Ambient conditions	
Operating temperature	-5...+40 °C
Storage temperature	-20...+70 °C
Operation in humid environments (without moisture condensation)	10...90 % rel.
Storage in humid environments (without moisture condensation)	5...90 % rel.
Dimensions and weights	
W x H x D mm	71 x 61 x 30
Weight	100 g
Protection category (IEC 60529)	IP41
Standards	EN 54-16

Loop isolator (100V)

	PCA2005-A1
Supply	
Operating voltage	AC 16...100 V
Operating power	75 mW nominal 150 mW in startup
Line separating function	
Pilot tone frequency	
• Normal mode	20 kHz with configured On/Off-time
• Alarm mode	21 kHz
Line voltage at pilot tone frequency:	
• Minimum	AC 16 V
• Nominal	AC 25 V
• Maximum	AC 100 V
Voltage at which the 'Loop isolator (100V)' opens:	
• Minimum	AC 7 V
• Maximum	AC 9 V
Voltage at which the 'Loop isolator (100V)' closes:	
• Minimum	AC 4 V
• Maximum	AC 5.5 V
Currents:	
Max. switching current	2 A
Leakage current	150 µA
Max. serial impedance when switches are closed	0.2 Ohm
Technical data for each speaker tap on the loop isolator (100 V)	
Max. speaker output	12 W
Min. speaker output	0.75 W
Maximum cable length with monitoring	0.8 m
Maximum cable length without monitoring	100 m

	PCA2005-A1
LED connection	
Recommended color	Red
Diode bias voltage	< 2.2 V
Voltage	3 V
Current	5 mA
Series resistance, internal	150 Ω
Technical data for loop, amplifier and loop audio matrix	
Maximum number of speaker loops:	
Per amplifier channel	2
Loop audio matrix	8
Loop audio matrix (configured as 'Priority only')	4
Maximum number of loop isolators (100 V) per loop audio matrix:	
Per loop	80
All loops	480
Maximum number of loop isolators (100 V) per amplifier output:	
1x 150 W (PV2003-A1)	80
1x 200 W (PV1001-A1)	80
1x 250 W (PV2001-A1, PV2007-A1)	80
1x 300 W (PV2003-A1 bridge mode)	80
1x 500 W (PV2001-A1 bridge mode, PV2002-A1, PV1002-A1)	80
Usable with loop audio matrix	PC1001-A3, PC1002-A3 and PC2003-A1
Amplifier power calculation for loop isolator (100 V)	
Per loop isolator (100 V)	0.5 W
Maximum audio payload (according to calculation method below): ¹⁾	
1x 150 W (PV2003-A1)	110 W with 80 loop isolators (100 V)
1x 200 W (PV1001-A1)	160 W with 80 loop isolators (100 V)
1x 250 W (PV2001-A1, PV2007-A1)	210 W with 80 loop isolators (100 V)
1x 300 W (PV2003-A1 bridge mode)	260 W with 80 loop isolators (100 V)
1x 500 W (PV2001-A1 bridge mode, PV2002-A1, PV1002-A1)	460 W with 80 loop isolators (100 V)

	PCA2005-A1
Connections	
Design	Spring type
Cable diameter	Min.: 0.75 mm ² Max.: 2.5 mm ²
Loudspeaker cable: ²⁾	
Maximum cable length per amplifier output	1000 m
Cable types, untwisted only	FP30/60 NYM, 2 x 1.5 mm ² ISTY 2 x 2 x 0.8 mm ²
Ambient conditions	
Operating temperature	-5...+40 °C
Storage temperature	-20...+70 °C
Operation in humid environments (without moisture condensation)	10...90 % rel.
Storage in humid environments (without moisture condensation)	5...90 % rel.
Dimensions and weights	
W x H x D mm	70 x 116 x 25
W x H x D mm (housing)	85 x 135 x 37
Weight	80 g
Weight (with housing)	138 g
Standards	EN 54-17 with housing PCA2013-A1

¹⁾ Calculation of the maximum audio payload:

- The maximum audio payload per amplifier channel depends on how many loop isolators (100 V) are connected.

'Audio payload' [W] = 'power of the amplifier channel' – ('number of loop isolators' * 0.5 W)

²⁾ Twisted cable types are not permitted.

Spelsberg i 16-L Li Box

	PCA2013-A1
Rated insulation voltage	AC 400 V
Conductor cross-section	Max. 2.5 mm ²
Ambient conditions	
Operating temperature	-25...+40 °C
Max. operating temperature (24 hours)	35 °C
Max. air humidity at 25 °C (short-term)	95 % rel.
Max. air humidity at 40 °C	50 % rel.
Dimensions and weights	
W x H x D mm	130 x 85 x 37
Weight	58 g
Material	
Box	Polyethylene
Cover	Polypropylene
Protection category and color	
Protection category (IEC 60529)	IP55
Color	Gray

RJ45 interface

	PNA2008-A1
Connections	
Copper	1 RJ45 connector 9 screw terminals 0.2...4 mm ²
Network standards	Conforms to IEEE 802.3, 100Base-TX, 10Base
Ambient conditions	
Operating temperature	-20...+70 °C
Storage temperature	-20...+70 °C
Operation in humid environments (without moisture condensation)	10...90 % rel.
Storage in humid environments (without moisture condensation)	5...90 % rel.
Dimensions and weights	
W x H x D mm	34 x 45 x 83
Weight	40 g
Standards	EN 54-16

ICPDAS I-7510 (RS485, isolated)

	PNA2009-A1
Supply	
Power supply	DC 24 V (10...30 V)
Power consumption	2.2 W
Current consumption	90 mA at 24 V
Protection	Power reverse Over-voltage Brown-out
Interfaces	
Serial interfaces	Asynchronous half-duplex 2-wire RS-485
Transmission speed	300...115200 bps
Max. cable length	400 m at 115200 bps
Isolation	
Isolation type	2-way optical isolation
Isolation voltage	DC 3000 V
Connections	
Screw terminals	2 x plug-in10 pin connector block
Ambient conditions	
Operating temperature	-25...+75 °C
Storage temperature	-25...+75 °C
Humid environments (without moisture condensation)	10...90 % rel.
Dimensions and weights	
W x H x D mm	72 x 122 x 35
Weight	900 g
Standards	EN 54-16

RS485 module (1 port)

	PN1002-A1
Supply	
Power supply	DC 24 V (18...28 V)
Power consumption	2.2 W
Current consumption	25 mA
Protection	Over-voltage Short circuit Earth fault detection
Interfaces	
Serial interfaces	Standard RS485 to 3.3 V UART
Isolation	
Isolation voltage	DC 1600 V
Connections	
Pluggable connection terminals	8 pin connector block or 1x RJ45 connector
Ambient conditions	
Operating temperature	-5...+40 °C
Storage temperature	-5...+40 °C
Operation in humid environments (without moisture condensation)	10...90 % rel.
Storage in humid environments (without moisture condensation)	10...90 % rel.
Dimensions and weights	
W x H x D mm	120 x 71 x 35
Weight	139 g
Standards	EN 54-16

Input/output module FDnet/C-NET

	FDCIO221
Supply	
Operating voltage	DC 12...33 V
Operating current (quiescent)	Max. 0.4 mA
Relay output (ohmic)	AC 22 V, 2 A, max. 44 VA DC 30 V, 2 A, max. 60 W
Line resistance (input)	Max. 20 Ω
Communication protocol	FDnet/C-NET
Connection terminals	0.2...2.5 mm ²
Ambient conditions	
Operating temperature	-25...+70 °C
Storage temperature	-30...+75 °C
Air humidity (non-condensing)	≤95 % rel.
Color	
• Housing	~RAL 9010, pure white
• Cover	Transparent matt
• Housing FDCH221	~ RAL 9010, pure white
Protection category (IEC 60529)	
• When mounted on a U-rail in a fire control panel	IP30
• With housing FDCH221	IP65
Standards	EN 54-17, EN 54-18
Approvals	
• Vds	G209067
• LPCB	531h/02
• FM	3038448
• DNV GL (Marine)	MEDB00003UU
System compatibility	
• FDnet	FS20
• C-NET	FS720

	FDCIO222	FDCIO224
Supply		
Operating voltage	DC 12...33 V	
Operating current (quiescent)	Max. 0.75 mA	
Relay output	AC 250 V / 4 A, max. 1000 VA DC 30 V / 4 A, max. 120 W	
Communication protocol	FDnet/C-NET	
Connections		
• Pluggable connection terminals	0.2...1.5 mm ² (with 2.5 mm ² connection terminal DBZ1190 AB)	
• MC link	Plug connection 3.5 mm jack socket	
Ambient conditions		
Operating temperature	-25...+60 °C	
Storage temperature	-30...+65 °C	
Air humidity (non-condensing)	≤95 % rel.	
Color		
• Housing	~RAL 9010, pure white	
• Cover	Transparent matt	
• Housing FDCH221	~ RAL 9010, pure white	
Protection category (IEC 60529)		
• When mounted on a U-rail in a fire control panel	IP30	
• With housing FDCH221	IP65	
Standards	CEA GEI I-084	
Approvals		
• Vds	G204029	G207001
• LPCB	531m/02	-
• FM	3029351	3029351
• DNV GL (Marine)	MEDB00003UU	MEDB00003UU
System compatibility		
• FDnet	FS20, AlgoRex, SIGMASYS	
• C-NET	FS720	

	FDCIO223
Supply	
FDnet/C-NET operating voltage	DC 12...33 V
Operating current	Max. 0.75 mA
Maximum current connection factor	3
External power supply	
Input voltage	DC 18...32 V
Operating current without secondary load at 24 V	26 mA (typ.) 60 mA (max.)
Operating current with secondary load	Max. 2 A
Inputs/outputs as:	
Collective detector line/conventional detector line	110 series, MS9, Sigmacon, AlgoRex, Synova600, Synova300, Apollo Series 65 / Orbis or similar
<ul style="list-style-type: none"> Collective detector key figures KMK 	32
<ul style="list-style-type: none"> Terminal resistance 	20 V Transzorb diode or EOL22 (Ex)
Control output	DC 24 V \pm 5 % / max. 1x 1.5 A or 2x 1 A (fuse on 24 V supply line and on output side)
Contact input <ul style="list-style-type: none"> Terminating resistor combinations 	3.3 k Ω / 680 Ω , 2.7 k Ω / 560 Ω , 3.3 k Ω
Ambient conditions	
Operating temperature	-25...+60 °C
Storage temperature	-30...+65 °C
Air humidity	\leq 85 % rel. (no freezing or condensing at low temperature)
Communication protocol	FDnet/C-NET
Connections	
Pluggable connection terminals	0.2...1.5 mm ² (with 2.5 mm ² connection terminal DBZ1190-AB)
MC link	Plug-type connection, 3.5 mm jack socket
Color	
Housing	~RAL 9010, pure white
Cover	Transparent matt
Housing FDCH221	~RAL 9010, pure white

	FDCIO223
Protection category (IEC 60529)	
When mounted on a U-rail in a fire control panel	IP30
With housing FDCH221	IP65

TAS ULE-614 Dialer PCA2015-A1

	PCA2015-A1
Supply	
Operating voltage	DC 24...42 V (1.6 W)
Operating current (quiescent)	38...66 mA
Interfaces (connections)	
LAN interface	10/100 Base T(x) (VoIP with SIP-Protocol) or ISDN basic access (S0 multiple unit bus subscribers), by configuration selectable
Impedance audio line in	13 k Ω
Impedance audio line out	350 Ω
Audio input and output	4 wire interface Potential-free on transformer
Switching contact	PTT via VOX control Potential-free
Audio, switching contact and 1 signal input	Via M12-8 pin connector
Switching outputs	2 Remote controlled, potential-free
Switch inputs for external contacts	2
Outputs and inputs via M8 4-pin connector	Externally tappable Potential-free fault signal
Output	RJ12
Ambient conditions	
Operating temperature	0...+40 °C
Storage temperature	-25...+70 °C (non-condensing)
Operation in humid environments (without moisture condensation)	<93 % according to IEC 60068-2-3
Storage in humid environments (without moisture condensation)	≤ 30 °C ≤ 60 % rel.
Housing type	Aluminum profile housing (or 19" housing 3 HU/6 DU)
Dimensions and weights	
W x H x D mm	180 x 109 x 35
Weight	750 g
Standards	EN 54-16

Müller SC 95.47 PRO Clock PCA2016-A1

	PCA2016-A1
Supply	
Operating voltage	230 V, 50...60 Hz or DC 24 V with max. 3 A
Operating current (quiescent)	Max. 3 A
Receiver	DCF77 or GPS
Housing type	Self-extinguishing thermoplastic 19" housing (2 HU, 48 DU)
Ambient conditions	
Operating temperature	-30...+50 °C
Storage temperature	-30...+50 °C
Humid environments (without moisture condensation)	Max. 95 % rel. (non-condensing)
Dimensions and weights	
W x H x D mm	483 x 86 x 203
Weight	2.7 kg
Protection category	
Protection category (IEC 60529)	IP 20
Standards	EN 54-16

ITEC CD/USB/SD-Player PCA2019-A1

	PCA2019-A1
Supply	
Operating voltage	230 V / 50 Hz
Connection	
Stereo RCA-jack	775 mV line level output
Housing type	19" / 1 HU steel housing
Ambient conditions	
Operating temperature	-25...+75 °C
Storage temperature	-25...+75 °C
Humid environments (without moisture condensation)	10...90 % rel.
Dimensions and weights	
W x H x D mm	482 x 315 x 44
Weight	4.5 kg
Standards	EN 54-16

Issued by
Siemens Switzerland Ltd
Smart Infrastructure
Global Headquarters
Theilerstrasse 1a
CH-6300 Zug
+41 58 724 2424
www.siemens.com/buildingtechnologies

© Siemens Switzerland Ltd, 2020
Technical specifications and availability subject to change without notice.

Document ID A6V11940275_en--_b
Edition 2021-03-12